

INSTALLATION AND MAINTENANCE GUIDE

TOUCH B / E / BRE

ELECTRONICALLY OPERATED SELF-CLOSING FAUCET



stern

STERN ENGINEERING LTD.

INDEX

- 1 TECHNICAL DATA
- 2 OPERATION
- 3 PACK CONTENTS
- 4 PRE-INSTALLATION INFORMATION
- 4-5 FAUCET INSTALLATION
- 5-8 FLOW TIME ADJUSTMENT
- 9 LOW BATTERY INDICATOR
- 10 BATTERY REPLACEMENT INSTRUCTIONS
- 10 MAINTENANCE
 - Filter cleaning instructions
 - Care and cleaning of chrome and special finishes
- 11 SERVICE CHECK LIST
- 12 SPARE PARTS LIST
- 13 LIMITED WARRANTY

TECHNICAL DATA

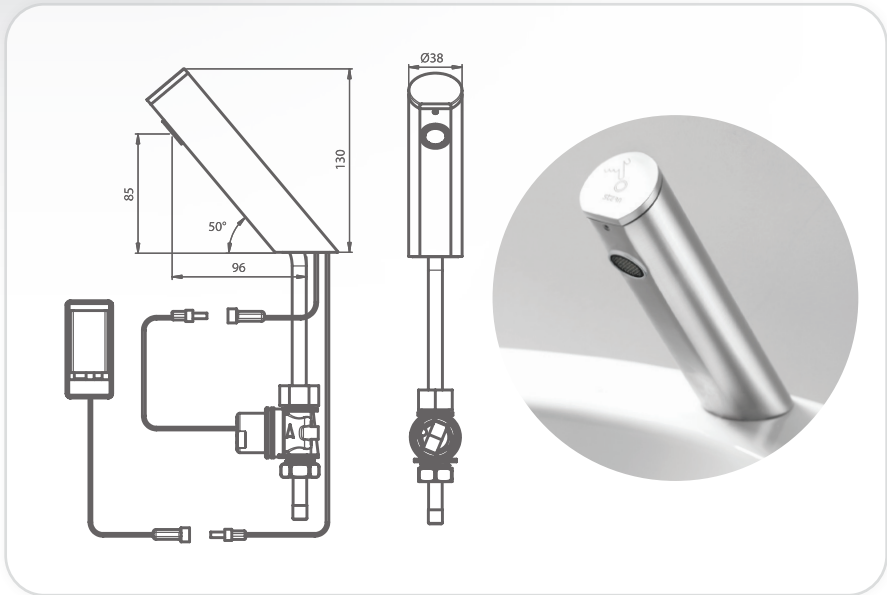

Product control:

Touch using Piezo technology

Installation:

Deck mounted

Hot water supply:

Max 70°C

Operating water pressure:

0.5-8.0 bar (7-116 PSI)

With water pressure of more than 8 Bars,
use a pressure reducing valve

Power specification:

9V low voltage system

Power source:

Touch B: 1 x 9V battery

Touch E and BRE: 9V transformer

Default flow time:

8 seconds

Programmable flow time:

1 – 60 seconds

OPERATION



TOUCH B and TOUCH E

To operate Touch, simply touch the designated area at the piezo cap. Default flow time is 8 seconds.

If you do not need more water, just touch the designated area again to stop the water flow before the default flow time has passed.

TOUCH BRE

This model features a permanent ring illumination.

To operate Touch BRE, simply touch the Piezo area in the middle of the light ring at the Piezo cap. A flow cycle of 8 seconds will be completed. The light will blink while water runs out of the faucet.

If you do not need more water, just touch the designated area again to stop the water flow before the default time has passed.



PACK CONTENTS

Familiarize yourself with the part names and confirm that the parts are included.



1x Tap and attachments



1x Filter



1x Allen key 2 mm

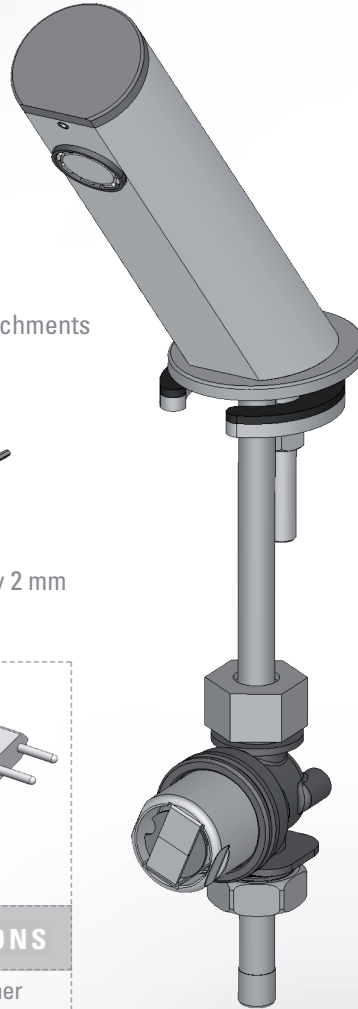
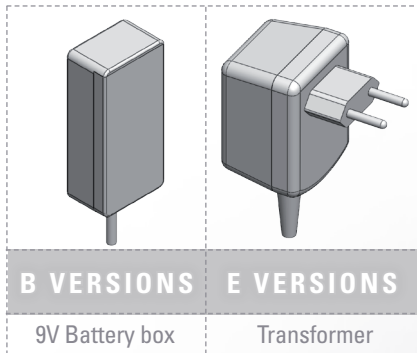

PRE-INSTALLATION INFORMATION

Check contents

Separate all parts from packaging and check each part with the Pack contents section.

Make sure all parts are accounted for before discarding any packaging material. If any parts are missing, do not attempt to install your Touch faucet until you obtain the missing parts.

Preparation for Installation:

Flush water supply lines thoroughly before installing the faucet. Do not allow dirt, Teflon tape or metal particles to enter the faucet.

Shut off water supply.

Important:

All plumbing is to be installed in accordance with applicable codes and regulations.

FAUCET INSTALLATION

Step 1 – Remove all mounting hardware

1. Shut off the water supply and remove the hexagonal nut, the disk and the gasket. Do not remove the O-ring from the base of the faucet.

Step 2 – Installing the faucet

1. Place the faucet with O-ring into the hole in deck or lavatory. Make sure the O-ring is located between the deck or lavatory and the bottom of the faucet.
2. Slide the gasket over the flexible hose.
3. Secure the faucet to deck or lavatory with the hexagonal nut and the disk.

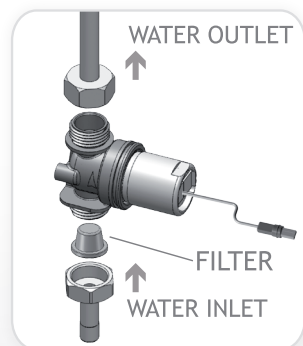

FAUCET INSTALLATION

Step 3 – Connecting the water supply

1. Fit the pipe to the housing of the solenoid valve. Important: inlet and outlet should follow the indicating arrow at the solenoid housing.
2. Fit the water supply inlet to the adapter at the solenoid valve housing.

Note: Make sure that the filter is assembled between the housing of the solenoid valve and the adapter.

Step 4 – Connecting the power source

1. For Touch B: Install the battery box at the wall under the sink using the screws or the two sided adhesive foam tape.

For Touch E / BRE: Plug the transformer into the electricity socket.

Important: In order to avoid entering into the adjusting mode, wait 10 seconds before operating the system.

2. Turn on the central water supply and the shut-off valves.
3. Check for leaks.

FLOW TIME ADJUSTMENT

Adjustment levels

The flow time is programmable on site. If necessary, the default flow time of 8 seconds can be adjusted to any value between 1 to 60 seconds. The Touch adjustment mechanism is composed of 3 adjustment levels for changing the flow time. An indicator light (LED) will guide you from one level to the other.

The following table shows the number of steps in each level, the duration of each step and how to recognize in what adjusting level you are.

	Level 1	Level 2	Level 3	Out of adjusting mode
No. of steps	10 steps	10 steps	2 steps	
Seconds to be increased by touching once	1 second	2 seconds	15 seconds	
Adjustment level indicator	Level 1 is reached once entering into adjusting mode	Indicator light blinks twice	Indicator light blinks 3 times	Indicator light blinks 4 times

FLOW TIME ADJUSTMENT

The following examples show how to manage the adjustment levels:

Example 1: You wish to adjust the flow time to 20 seconds.

At level 1 perform 3 steps of 1 second (you will get 3 seconds). Total: 3 seconds

Go to level 2 and perform 1 step of 2 seconds (you will get 2 seconds). Total: 5 seconds)

Go to level 3 and perform 1 step of 15 seconds (you will get 15 seconds). Total: 20 seconds.

Example 2: You wish to adjust the flow time to 45 seconds.

At level 1 perform 1 step of 1 second (you will get 1 second). Total: 1 second

Go to level 2 and perform 7 steps of 2 seconds (you will get 14 seconds). Total: 15 seconds)

Go to level 3 and perform 2 steps of 15 seconds (you will get 30 seconds). Total: 45 seconds.

Example 3: You wish to adjust the flow time to 60 seconds.

At level 1 perform 10 steps of 1 second (you will get 10 seconds). Total: 10 seconds

Go to level 2 and perform 10 steps of 2 seconds (you will get 20 seconds). Total: 30 seconds)

Go to level 3 and perform 2 steps of 15 seconds (you will get 30 seconds). Total: 60 seconds.

How to adjust the flow time in Touch B and Touch E

1) Open the piezo cap using the provided 2 mm Allen key.

2) Disconnect the power supply (batteries or transformer).

3) While the power source is disconnected, verify that the solenoid valve is installed and touch the piezo cap twice.

4) Then, reconnect the power supply.

5) The indicator light (LED) on the back of the Piezo cap will start blinking. After a few blinks the LED will give a steady red light. Touch the Piezo cap when the steady red light is still on to enter into the adjusting mode. When done correctly, the light will stop blinking.

Note: If you will not press at the indicated area, the previous adjustment will remain.



FLOW TIME ADJUSTMENT

6) By touching the Piezo cap the new flow time will be programmed. In adjusting mode level 1, each touch increases the flow time by 1 second with a maximum of 10 seconds. You will see the LED blinking every time that a new step is performed.

7) If your desired flow time is within 10 seconds, no other adjusting levels are needed and you can stop pressing the Piezo cap. The LED will blink 2 times, then 3 times and after 4 times you will leave the adjusting mode. The Touch is now adjusted to the desired flow time.

8) If you need to perform steps at adjusting level 2, wait after you see the LED blink twice and then, perform the needed quantity of steps (with a maximum of 10 steps of 2 seconds).

If you do not need more levels, stop pressing. The indicator light will blink 3 times and after 4

times you will leave the adjusting mode. The Touch is now adjusted to the desired flow time.

9) If you need to perform steps at adjusting level 3, wait after you see the LED blink 3 times and then, perform the needed quantity of steps (with a maximum of 2 steps of 15 seconds).

10) To leave the adjusting mode wait until the LED blinks 4 times. The Touch is adjusted to the desired flow time.



FLOW TIME ADJUSTMENT

How to adjust the flow time in Touch BRE

- 1) Disconnect the transformer.
- 2) While the power source is disconnected, verify that the solenoid valve is installed and touch the piezo cap twice.
- 3) Then, reconnect the power supply.
- 4) The light ring at the Piezo cap will start blinking. After a few blinks the light ring will give a steady light. Touch the Piezo cap when the steady light is still on to enter into adjusting mode. When done correctly, the light ring will stop blinking.

Note: If you will not press at the indicated area, the previous adjustment will remain.

- 5) By touching the Piezo area in the middle of the light ring at the Piezo cap the new flow time will be programmed. In adjusting mode level 1, each touch increases the flow time by 1 second with a maximum of 10 seconds. You will see the light of blinking every time that a new step is performed.
- 6) If your desired flow time is within 10 seconds, no other adjusting levels are needed and you can stop pressing the Piezo cap. The light will blink 2 times, then 3 times and after 4 times you will leave the adjusting mode. The Touch BRE is now adjusted to the desired flow time.
- 7) If you need to perform steps at the adjusting level 2, wait after you see the light blinking twice and then, perform the needed quantity of steps (with a maximum of 10 steps of 2 seconds)
- 8) If you do not need more levels, stop pressing. The light will blink 3 times, and after 4 times you will leave the adjusting mode. The Touch BRE is now adjusted to the desired flow time.
- 9) If you need to perform steps at the adjusting level 3, wait after you see the light blinking 3 times and then, perform the needed quantity of steps.(with a maximum of 2 steps of 15 seconds)
- 10) To leave the adjusting mode wait until the light blinks 4 times. The Touch BRE is now adjusted to the desired flow time.



LOW BATTERY INDICATOR

The Touch faucet has an advanced battery level management system consisting of two steps:

Step 1

The battery still has enough power to open and close the solenoid valve.

At this first step the battery level management system allows the solenoid valve to open and close but will activate a warning indicator light.

The LED at the back of the Touch cap will blink twice when the battery level management system has activated step 1 and the user touches the designated area.

Step 2

At his point the battery might not have enough power to open and close the solenoid valve.

The battery level management system does not allow the solenoid valve to open. Instead of providing an opening and closing pulse, the system provides two closing pulses.

The LED at the back of the Touch cap will blink three times when the battery level management system has activated step 2 and the user touches the designated area. Water will not flow since the solenoid will not be opened.

BATTERY REPLACEMENT

1. Carefully open the battery box.
2. Remove the old battery.
3. Replace the used battery with a new 9V battery. A Lithium battery is recommended.

Note: Do not allow moisture or water into the system

4. Close the box.
5. In order to avoid entering into the adjusting mode, wait 10 seconds before operating the system.

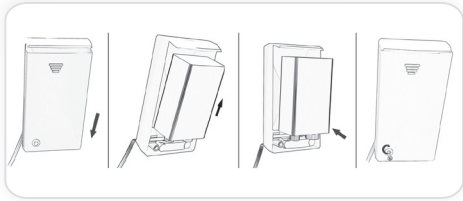

Important: Spent batteries should not be disposed of with normal household waste. Contact your local authority for information on waste disposal and recycling.



MAINTENANCE

Filter cleaning instructions

The Touch is provided with one stainless steel filter preventing foreign particles to enter the lines. If the water flow has decreased, this may be because the filter is clogged. The filter can be cleaned as follows:

1. Shut-off the water shut off valve.
2. Disconnect the water supply inlet from the adapter at the solenoid valve housing.
3. Remove the filter from the adapter and wash it under running water.
4. Reassemble the parts.
5. Reconnect the solenoid valve housing and restore the incoming water supply.
6. Make sure that there is no water leakage.

Care and cleaning of chrome and special finishes

DO NOT use steel wool or cleansing agents containing alcohol, acid, abrasives, or the like. Use of any prohibited cleaning or maintenance products or substances could damage the surface of the faucet. For surface cleaning of faucet use **ONLY** soap and water, then wipe dry with clean cloth or towel. When cleaning bathroom tile, the faucets should be protected from any splattering of harsh cleansers.

SERVICE CHECK LIST

No water is coming out of the faucet

Check the batteries. Low or used up batteries. Replace the batteries. See page 10.

Check the flow time. See page 5.

Check the connection between the piezo cap connector and the solenoid connector.

Check that the battery box is correctly connected.

Check the solenoid valve. If debris or scale are present, unscrew the solenoid valve, pull out the plunger and the spring and clean them.

Use scale remover if needed. When replacing the spring, make sure that it is in vertical position.

Check the diaphragm. If needed, clean the orifice or replace it.

Check the water supply pressure. It must be 0.5-8.0 bar (7-116 PSI) . With water pressure of more than 8 Bars, use a pressure reducing valve.

Check the flow time. If needed adjust it following the instructions at page.

Check the solenoid valve. If debris or scale is present, unscrew the solenoid valve, pull out the plunger and the spring and clean them.

Use scale remover if needed. When replacing the spring, make sure that it is in vertical position.

Water flow does not stop

Water flow diminished

Check the filter. If needed, remove it , clean it and reinstall it. See page 10.

SPARE PARTS LIST

PART NAME	PART CODE
Solenoid Valve Kit for Touch B or E	07230017
Solenoid Housing Kit / Solenoid Housing Kit USA	07231008 / 07231009
Seals and Screws Kit	07210081
Cover Kit for Touch B or E	07270031
Cover Kit for Touch BRE	07270160
Diaphragm	04500001
Battery Box for 1 x 9V battery	06530008
IP 67 Battery Box for 6 x 1.5 AA batteries	06530020
Transformer	06522042
Solenoid valve kit for Touch BRE	07230039

LIMITED WARRANTY

Y. Stern Engineering Ltd. warrants that its electronic faucets, flush valves and controls will be free of defects in material and workmanship during normal use for two years from the date the product is purchased.

If a defect is found in normal use, Y. Stern Engineering Ltd. will, at its discretion, repair, provide a replacement part or product, or make appropriate adjustments. Damage caused by accident, misuse, or abuse is not covered by this warranty. Improper care and cleaning will void the warranty. Proof of purchase (original sales receipt) must be provided to Stern Engineering Ltd. with all warranty claims.

Stern Engineering Ltd is not responsible for labor charges, installation, or other incidental or consequential costs other than those noted above. In no event shall the liability of Stern Engineering Ltd. exceed the purchase price of the faucet, valve or control.

If you believe that you have a warranty claim, contact your Stern Distributor, Dealer or Plumbing Contractor. Please be sure to provide all pertinent information regarding your claim, including a complete description of the problem, the product, model number, the date the product was purchased, from whom the product was purchased and the installation date. Also include your original invoice.

Y. STERN ENGINEERING AND/OR SELLER DISCLAIM ANY LIABILITY FOR SPECIAL, INCIDENTAL OR CONSEQUENTIAL DAMAGES. This warranty excludes product damage due to installation error, incorrect maintenance, wear and tear, battery, water composition, product abuse, or product misuse, whether performed by a contractor, service company, or the consumer. This warranty does not cover product damage caused by the following:

- Incorrect installation, inversions of supply pipes.
- Pressures or temperatures exceeding recommended limits.
- Improper manipulation, tampering, bad or lapsed maintenance.
- Foreign bodies, dirt or scale introduced by the water supply.

stern

STERN ENGINEERING LTD.

15 Gan Rave Blvd., 81222 Gan Rave, Yavne, Israel

Tel: 972-8-9326000, Fax: 972-8-9326025, export@sternfaucets.com

www.sternfaucets.com



RoHS

04.13 015225100-C